



Universal Ignition TCI V4.0

Short characteristics of Ignition

The ignition is development for the two or four-cycle automobile and motorcycle engines. The ignition allow the programmable advance curve and intensity of the excitation two inductors. All the functions and optional working ignition regimes can be set by a personal computer. For this reason there is a program **Ignition Control** that also enables online visual control of real values of turns, advance (set-up time). To connect the personal computer through ignition the standard extension cable of RS232 link should be used.

The advance directing is realized by the ignition microprocessor that sets the delay time of ignition (the ignition advance) according to the set curve and actual turns.

Using the extension function input *Ex* it possible change over the ignition curves. The advance directing is realized by the conversion of asked advance curve into schedule of time delays. Depending on actual turns of a motor the individual time delays are chosen from the schedule and via the microprocessor exactly measured and that is how the final effect of set up directing works.

The application **Ignition Control** newly provides the function of advance debugging by acceleration brake where the acceleration of motor is watched when repressing its own mass. The acceleration of motor turns is adequate to the twisting moment, which is a condition.

Main features

- ✓ The induction ignition type - TCI
- ✓ Supply voltage range 3,5 to 25V
- ✓ Engine working speed 0 to 25.000 rpm
- ✓ Working temperature range -40 to 85°C
- ✓ Used rugged connectors FASTON
- ✓ Protection cover IP54
- ✓ Communication by COM port (RS232)
- ✓ Two selectable advance curve
- ✓ Selectable exciting inductive coil curve
- ✓ Direction capacitive coil e.g. VAPE Z67, Z58, Z69, Z83
- ✓ Extended function EX (DI1, DI2, AI1, AI2)
- ✓ Observation actual state of engine
- ✓ Change curves during engine work
- ✓ Engine work time record
- ✓ Acceleration brake

Main Features

Parametes	Range
Supply voltage	3.5 to 25V, (over voltage protection 33V)
Engine working speed	0 to 25,000 rpm
Advance control	0 to 90°
Working temperature	-40 to 85°C
Engine speed for advance control	180 to 20,500 ot/min
Flash energy	Table, Max., Med., Min., Direct
Inductor coil current (1A, 1B)	Max. 15A/0,085Ω (MOSSFET)
Pulse direction capacitive coil (1A, 1B)	Pulse width 3 to 500us (Pull up 1kΩ)
Inductor coil resistance	> 2.5Ω (12V)*, > 1.5Ω (6V)*
Supply voltage for a rotating sensor	+5V/100mA
Extended input (Ex = DI1,DI2,AI1,AI2)	DI (0 to 1V = L, 3 to 20V = H), AI (0 to 5V)
Auto. disconnection inductors	5 to 120s after stop of engine
State signalization by LED diode	Red, Green
Communication with PC through COM port	yes
Protection cover	IP54
Package size	120x68x28 mm
Weight	200g

* measuring between inductor coil pin 1(switching) and 15(supply)

Connector scheme



Sign of wires

SIGN	Description	RANGE
+	Supply	3.5 to 25V, (over voltage protection 33V)
G	Ground	0V
1A	Inductor coil power switch A	Max. 15A/0,085Ω (MOSSFET)
1B	Inductor coil power switch B	Max. 15A/0,085Ω (MOSSFET)
+5V	Sensors supply output +5V	+5V, 100mA
P	Rotating sensor	-60 až 60V, rise edge 0 -> 1.2V
Ex	Extended input	DI (0 to 1V = L, 3 to 20V = H), AI (0 to 5V)

Installation

The electronic ignition works with safe voltage up to 25V but also switches the inductance load where several thousands voltages come up. Therefore it is necessary to work absolutely cautiously and any changes of electrical ignition installation must be done always when the power supply is switched OFF.

The power supply and all ignition inputs are protected against the over voltage or reversing of polarity. These states cannot be permanent because the safety components may get overburdened and part or full damage of ignition function may happen.

The ignition outputs are not insured against the short circuit and the direct joining to output 1A, 1B must not occur. The joining to impedance which would cause exceeding of permitted current and following destruction of existing switch on component in the ignition is impermissible.

The right and reliable function of installed device is a subject to the right power supply. All used wattage lines (G, 1A, 1B) must be of minimum 1,5mm diameter. The power supply must be always realized through security component item (safety fuse 10A), that protects the ignition in case of reversing of polarity, over voltage or another failure.

Instalation scheme

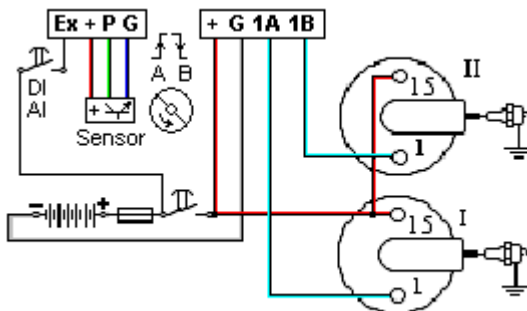

Main scheme in variant with two inductors.

Note.: Input Ex needn't connect. It is extension function only.

For engine with one inductors you can connect 1A or 1B output only

Conection scheme of the engine rotation sensor

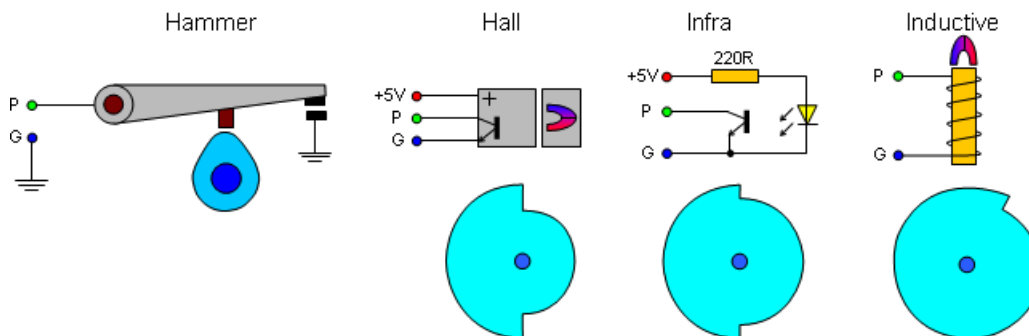

The advance set up

The last and the most important point in the installation are the proper settings of the ignition to serve all demanded functions perfectly.

First it is necessary to know what maximal advance each engine demands in the first period. This maximal advance must be set in the reading sensor of rotation (e.g. 35°) and also be held as a reference value in the program in a Advance *curve* bookmark, item *Rotation Reading Sensor*. Always the value of advance set in the sensor must be adequate to the value set in the program. According to this value the conversion of the ignition advance curve is saved in a schedule, mainly the actual truth of *On-line visualisation*. The value of advance on the rotation reading sensor can be corrected later by comparing the actual value of ignition found out e.g. by a stroboscope to the value of advance set in *On-line visualisation*.

Rotate trigger position on dead point

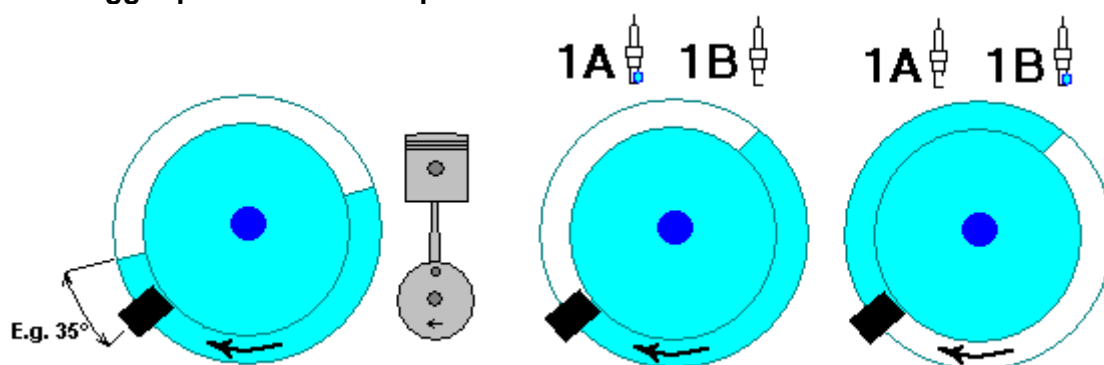

The advance directing is realized by the ignition microprocessor that sets the delay time of ignition (the ignition advance) according to the set curve and actual turns.

For easier set up the ignition advance is determined in [mm] in motorbike engines. That is why this program enables the automatic ignition conversion from [mm] to [°]. The ignition conversion window is activated by double click of the mouse in bookmarks *Ignition curve* and items *Rotation reading sensor*.

Signal indicator

The profile of all functions is saved in the ignition memory that keeps data even without power supply. The memory content is recorded from the Ignition Control program.

If the memory has never been recorded or the interruption of the last recording happened this state will be signaled by a short red flashing after switch-on. All set ups will then be given by a producer. The right memory content is indicated by a constant green light. The recording data from the computer is indicated by a red constant light. If the ignition changes into the protective mode (the engine is not running and the regime is allowed) the green indicator stops lightning (the inductors are not being excited). After getting the impulse from the rotation reading sensor the green indicator will switch on again (re-excitation).

Ignition Control Application

The electronic ignition consists of many functions and their set-up can be realized through a personal computer with Ignition Control program. The computer communicates through the *RS232* interface. That is why the computer must have at least one COM port and/or *USB/RS232* transducer. The application works under the *Windows 95* or higher. It requires 4MB of empty space in hard disc. The minimum PC configuration is *Pentium 166MHz, 32MB RAM* is accurate.

Ignition Control application is divided into four individual parts:

- Online visualisation
- Ignition advance curve
- Extended functions
- Sensor calibration

All parameters given in bookmarks *Ignition advance curve, Extended functions and Sensors calibration* can be saved into a file by the item in the main menu *File -> Save or File -> Save as ...*, then a dialog box for setting the file saving path will display. Afterwards the saved data can be opened by *File -> Open...* All data about the ignition advance curve, engine parameters and its sensors are saved to this file.

When changing the curve and other data some unwanted disruptions of the origin data may occur. In this case there is a function in the main menu *Edits -> Back* and *Edits -> Forward*. The program enables 19 edits back and then forward. There is *Edits -> Transmission...* for transmitting the ignition advance curve into the ignition. This function can be activated also by pressing the F2 key.



To set application parameters there is a dialog in the main menu *Settings -> Parameters ...* It is possible to set the language of the application.

The important function items from the main menu are available also in the speed key?

On-line visualisation

Always when installing, setting and processing devices it is necessary to have the possibility to check the installed device. The ignition provides the possibility of connection and getting the real values during running the engine. **The grey text is NOT valid for the ignition of Universal.**

On-line visualisation displays these basic parameters:

- Turns in the engine (choice channel A or B)
- Ignition advance (choice channel A or B)
- Network voltage (Board voltage)
- Digital inputs (Pa, Pb, DI1, DI2, DI3, DI4)
- Digital outputs (DO1, DO2)
- Analog inputs (AI1, AI2, AI3, AI4)
- Engine record working time
- Serial number and SW version of ignition

To run visualization it is always necessary to connect the computer with the ignition by a serial extended cable, to open the communication port and to run the visualization by pressing the button *Start*. In case that after pressing the button *Start* the real data do not display please control the connection of communication cable, the number of the used communication port and the voltage of the ignition.

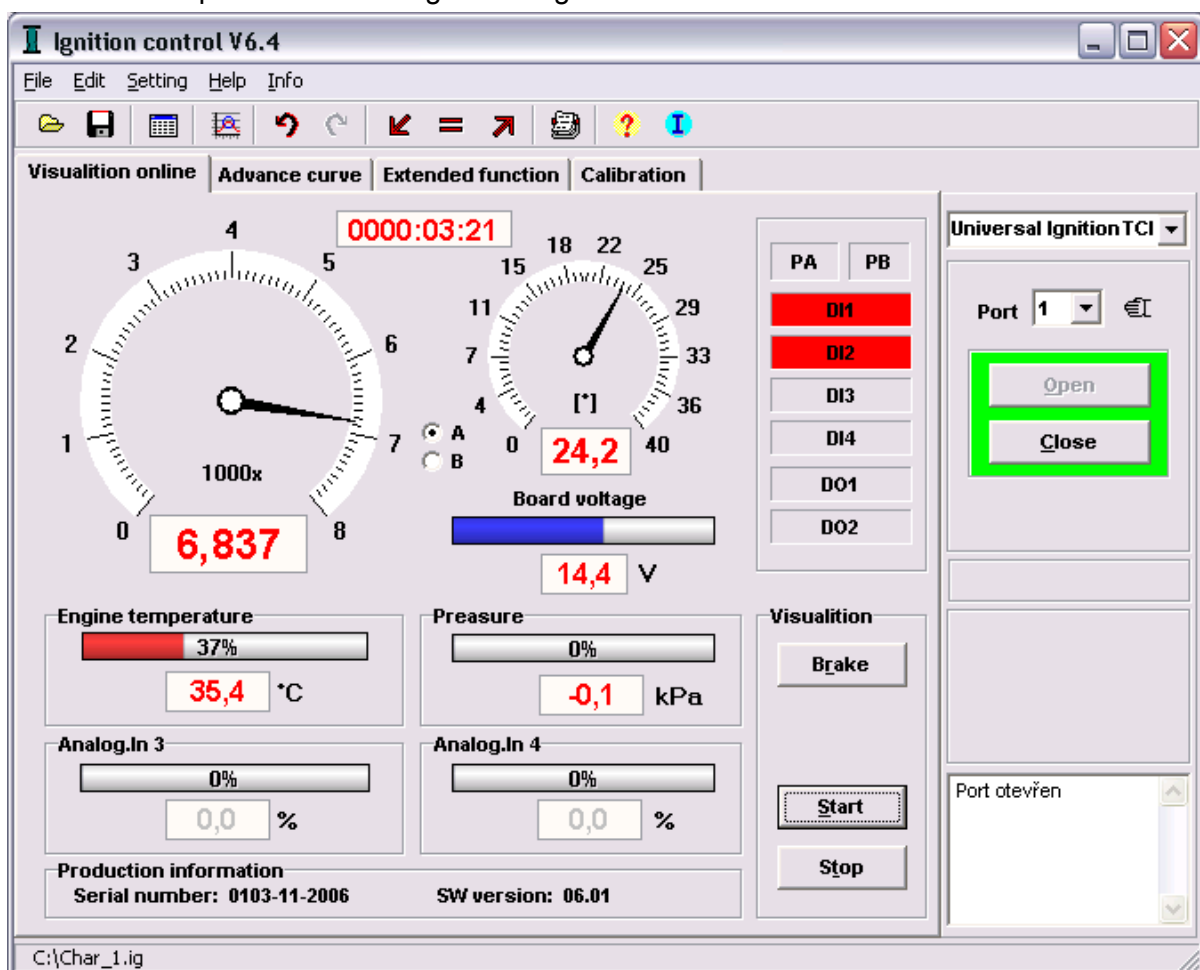

The ignition advance curve

The basic character of the ignition is the directing the ignition advance according to real turns of the engine. To set ignition advance directing characteristics there is *Ignition advance curve* bookmark.

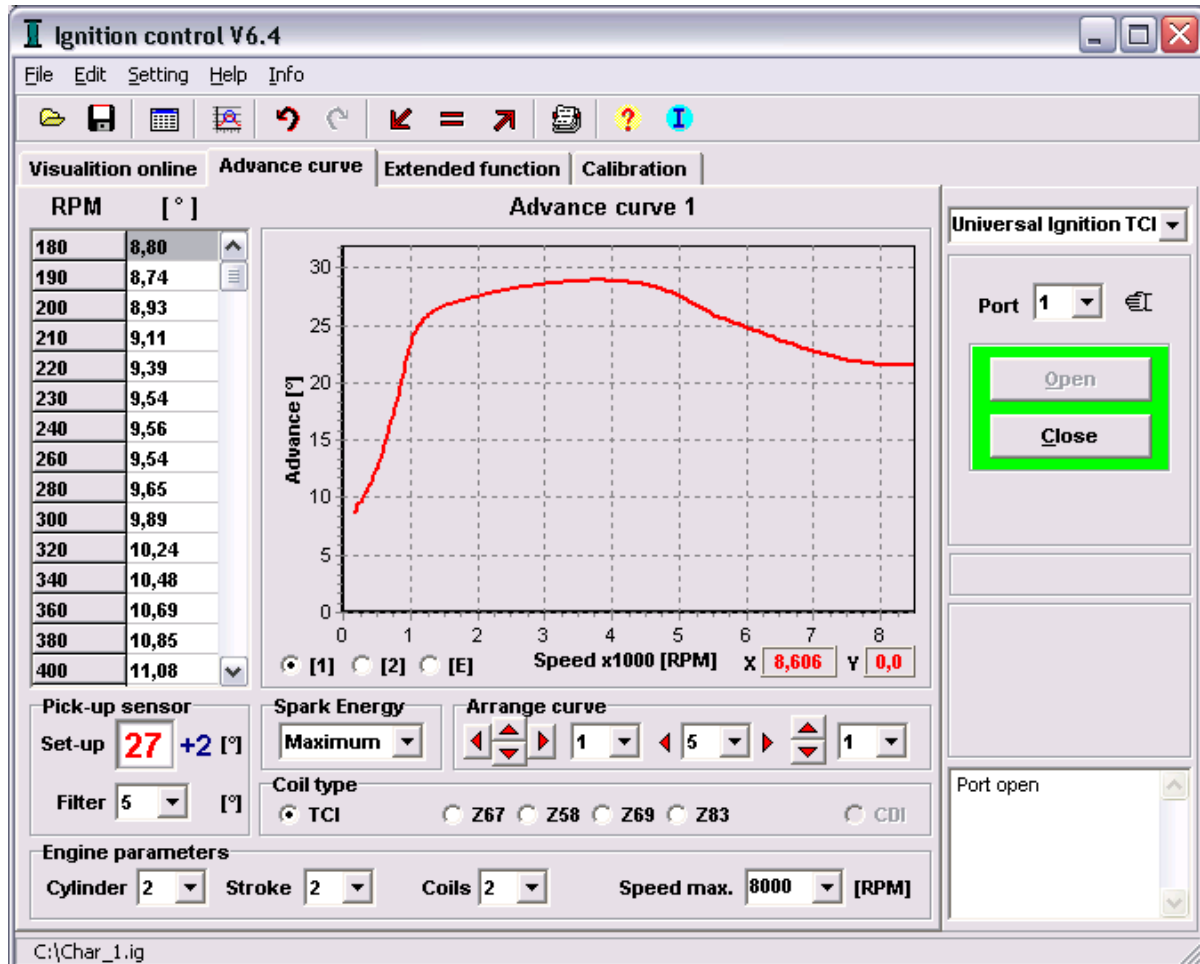

The defining of the maximal advance is the first step before setting the advance curve that will be set in the advance reading sensor and that must be set also in item *Advance reading sensor* (see Advance settings).



It is possible to activate the window for the advance conversion from [mm] to [°] by a double click of the mouse on *Advance reading sensor*. For the correctness of conversion it is necessary to set the value of the engine stroke.

After setting the reading sensor it is possible to continue with settings maximal allowed turns in *Maximal turns* item items *Maximal turns*. It is suitable to choose the nearest higher value from the offered turns.

Now the field of displaying the curve in the graph and its following conversions are determined.

- Edit curve... Ctrl+E
- Filter curve Ctrl+F
- Copy char. [1] => [2]
- Copy char. [2] => [1]

By a click of the right mouse button in the area of the graph or table the menu of functions for working with the curve will display.

To edit the curve easily there is *Curve Editor*. It enables a quick creation of an automatic curve tract with a linear or logarithmic tract or enables to specify a shortened table.

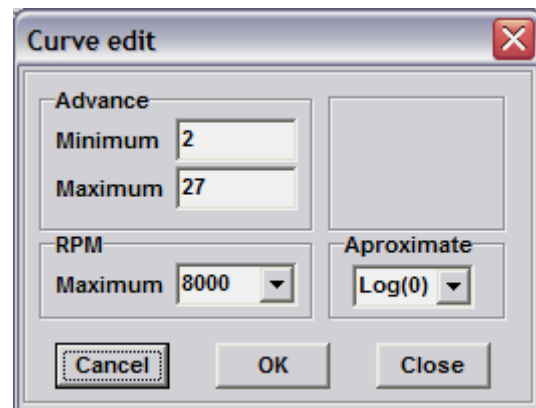

The curve tract can be edited by drawing the mouse away from the tract up or down. The width of space can be set between horizontal arrows in *Curve editing* panel. There are buttons here with vertical arrows that shift the curve according to the asked number of degrees.

When editing the curve the tract continuousness may brake. To correct it there is *Curve filter*. The effect of this filter can be emphasized by its repeated use.

It is possible to change the tracts of the curves 1 and 2 by items [1] a [2].

To optimize the type of the inductors and its excitation there is *Flash energy* button. It is necessary to set medium or minimum excitation that will protect the inductors against the over excitation and their over heating when using inductors with resistance lower than 4Ω (min 2,5Ω). If using the inductors with the resistance higher than 4Ω there is medium or maximal excitation settings. The settings of *Flash energy directing* that directs exciting according to values of board voltage is the compromise of the excitation inductors.

Board voltage	Control flash energy
< 9V	Maximum
9V – 11,5V	Medium
> 11,5V / < 3300RPM	Minimum
> 11,5V / 3300 až 6500RPM	Medium
> 11,5V / > 6500RPM	Maximum

It possible configuration coil current by exciting curve or table. You can set exciting from 20 to 95% per a round.

Predefined exciting of coils

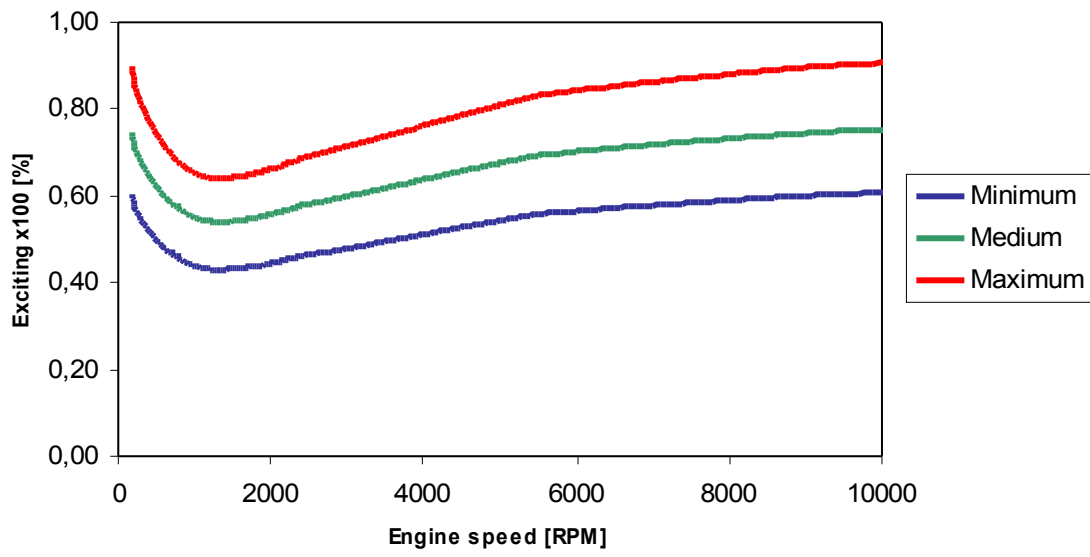

Extended functions

To increase safety of running and also for extended ignition advance curve settings possibilities there are extended functions. It is a file of digital inputs DI1, DI2 up to DI4, outputs DO1, DO2 and analogical inputs AI1, AI2 up to AI4. The functions of individual extending inputs and outputs can be permitted or inverted.

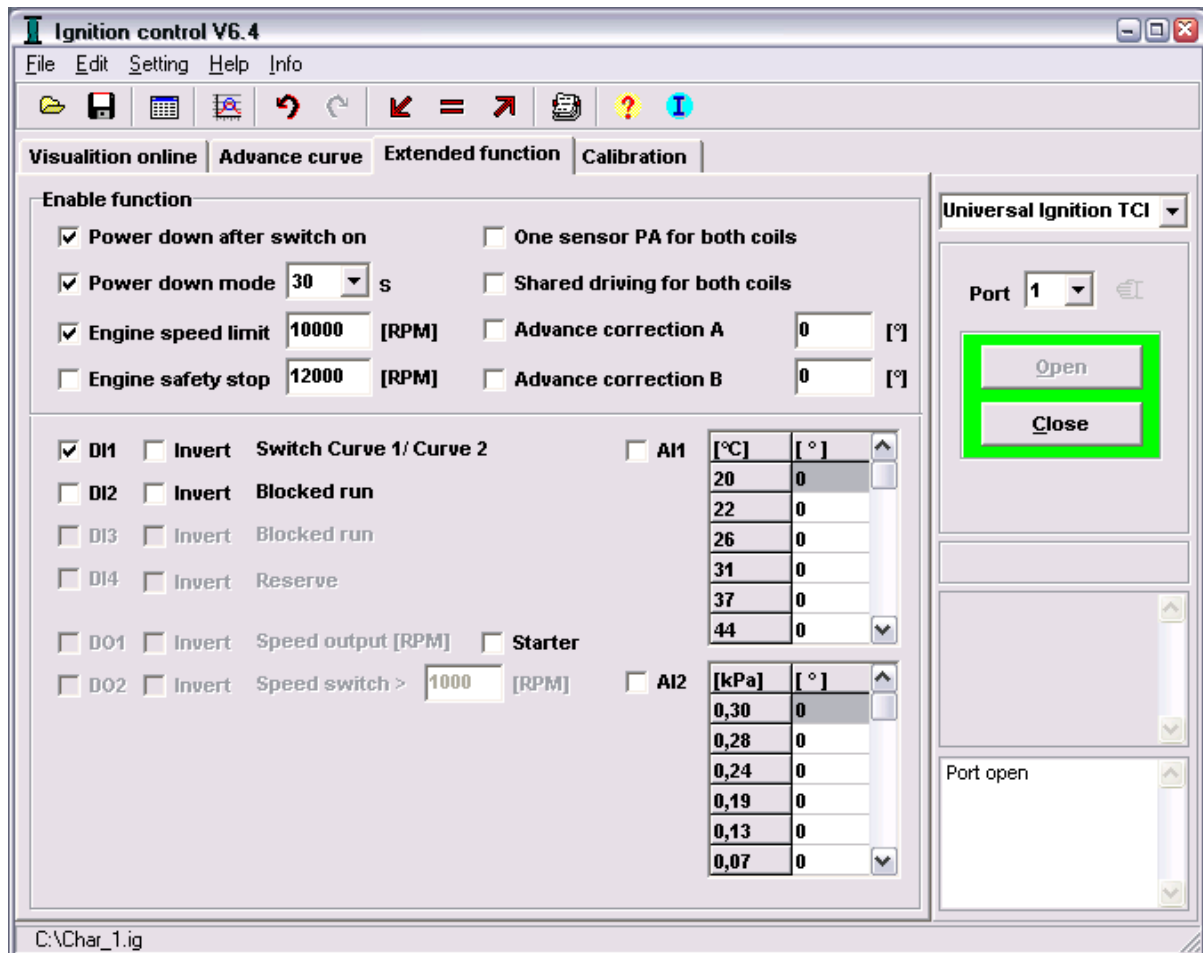

Power down - 5 up to 120s

Permitting to automatic inductor excitation switch-off after asked time of 5 up to 120s passed. It prevents from the inductor damage by permanent exciting current.

RPM limit -1000 up to 25000 turns/min

Permitting turn limit function causes regular interrupting of the inductor excitation after exceeding asked turn limits.

RPM stop - 1000 up to 28000 turns /min

Exceeding asked turns causes full interruption of excitation. It will be renewed when stopping the engine.

Advance correction A and B -15,5 up to 15,5°

Compensation asymmetrical crank

Shared driving of inductors

Switch independent to shared driving of inductors. Both output 1A and 1B are switching together.

DI1 - Switch Curve 1/Curve 2

It enables easy ignition advance curve switch-over whenever the engine is running. If the function is not active Curve 1 is used.

DI2 - Blocked run

It provides the immediate possibility of blocking the engine starting up or running.

DI3 - Blocked run'

It provides the immediate possibility of blocking the engine starting up or running.

DI4 - Reserve

The reserved input for the future use.

DO1 - Switch [x1/min]

Output to the speed counter.

DO2 - Switch RPM [1/min]> Asked turns

Output switched according to asked number of turns.

AI1, AI2 – Advance correction

It enables change of advance curve by analog signal (temperature, pressure or resistance sensor)

Sensor Calibration

It is important to know the working states of chosen working values for the optimal engine diagnostics. There are four analogical inputs to read signals from working state values sensors.

The inputs AI1 and AI2 have adjustable limits 0–5V. The other inputs AI3 and AI4 have the concrete limits 0-5V. Alternatively inputs DI3 and DI4 can be used as digital inputs.

The sensor calibration enables settings of the input name, units and signal conversion table of limits 0 up to 100% to the values responding the real signal e.g. °C, kPa, %, etc. It is necessary to set minimally two values in the table that can be both plus or minus.

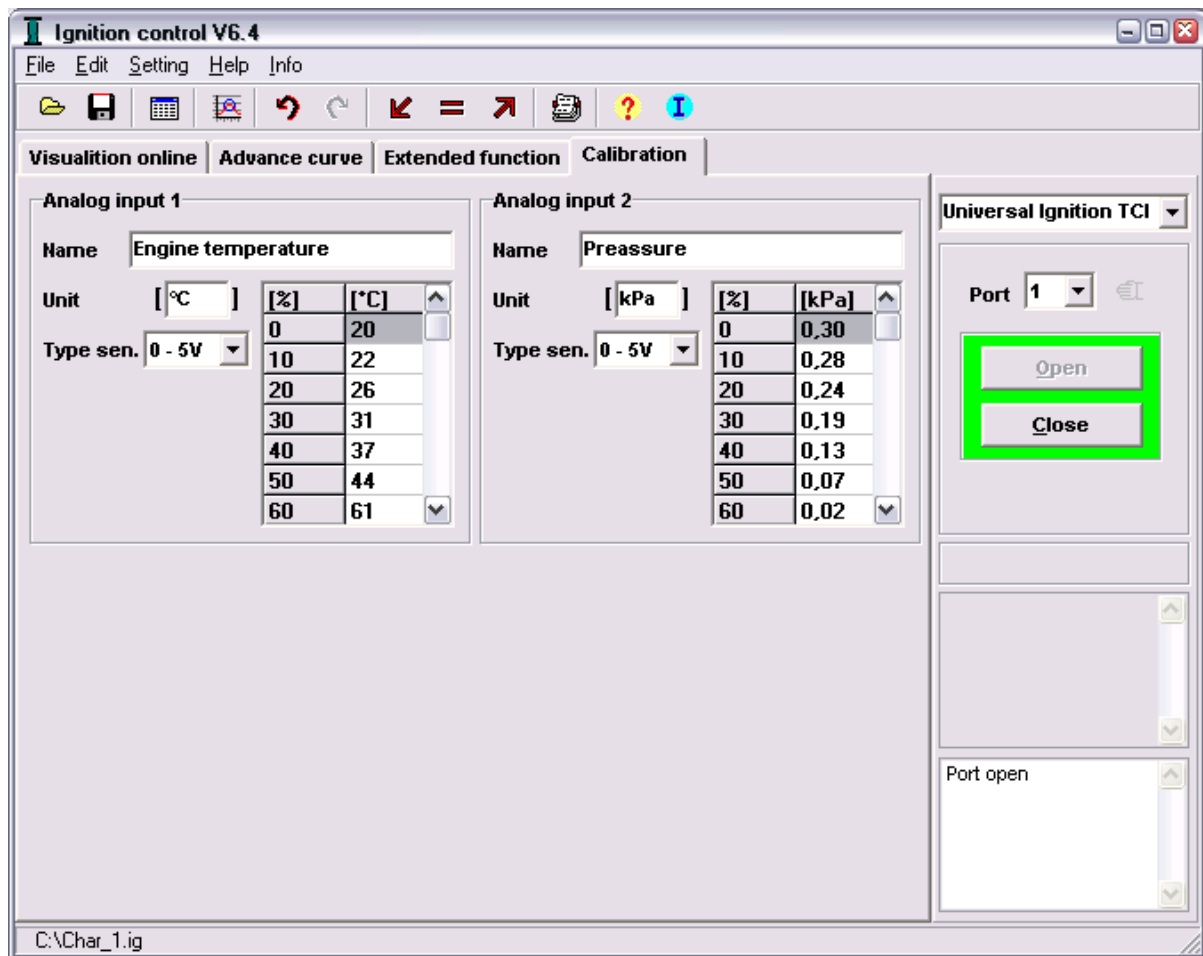

Process of Sensor Calibration:

- Enter the type of output signal from the sensor to *Sensor Type* items (0 up to 2,5V; 0 up to 5V; 0,2 up to 2,5kΩ; > 2,5kΩ)
- Level down the measured value around the sensor (e.g. temperature) to minimum.
- Increase the measured value around the sensor fluently up to maximum when the measured signal in input measured limits reaches some of values of 0, 10, 20 ... 100%. Write it to the right line referring to right input.

Sensors calibration example:

Analog input 1

Name Engine Temperature

Unit [°C] [V] [%] [°C]

Type sen. 0 - 5V

0	2
10	22
20	26
30	31
40	37
50	44
60	61

bookmark Calibration – sensor calibration

- 0,0V(0%) = 20°C
- 0,5V(10%) = 22°C
- 1,0V(20%) = 26°C
- 1,5V(30%) = 31°C
- 2,0V(40%) = 37°C
- 2,5V(50%) = 44°C

AH1

[°C]	[°C]
20	2
22	-4
26	-2
31	0
37	0
44	0

bookmark Extended function – advance corection by calibrated sensors – for temperature 22°C is decrease advance about 4°

Acceleration brake

There is a new function in *Online visualization*. It is *Acceleration brake* that realizes fast 5 second engine record with the calculation of the turn derivation (acceleration). It proportionately responds to torsional moment.

Measure process

- Check the *Engine Turn Limits* settings before use
- Leave the engine run idly and get ready for its acceleration
- Press Start button
- Wait exactly 1 second to run the record

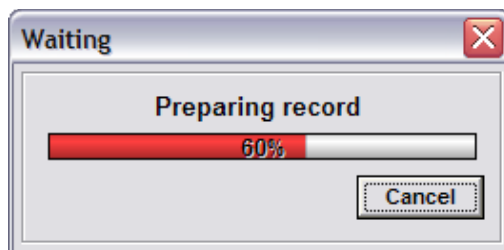

- Running of the record for 5 seconds
- End up the record and read the measured values of turns from ignition
- Display and conversion the measured values to the graph

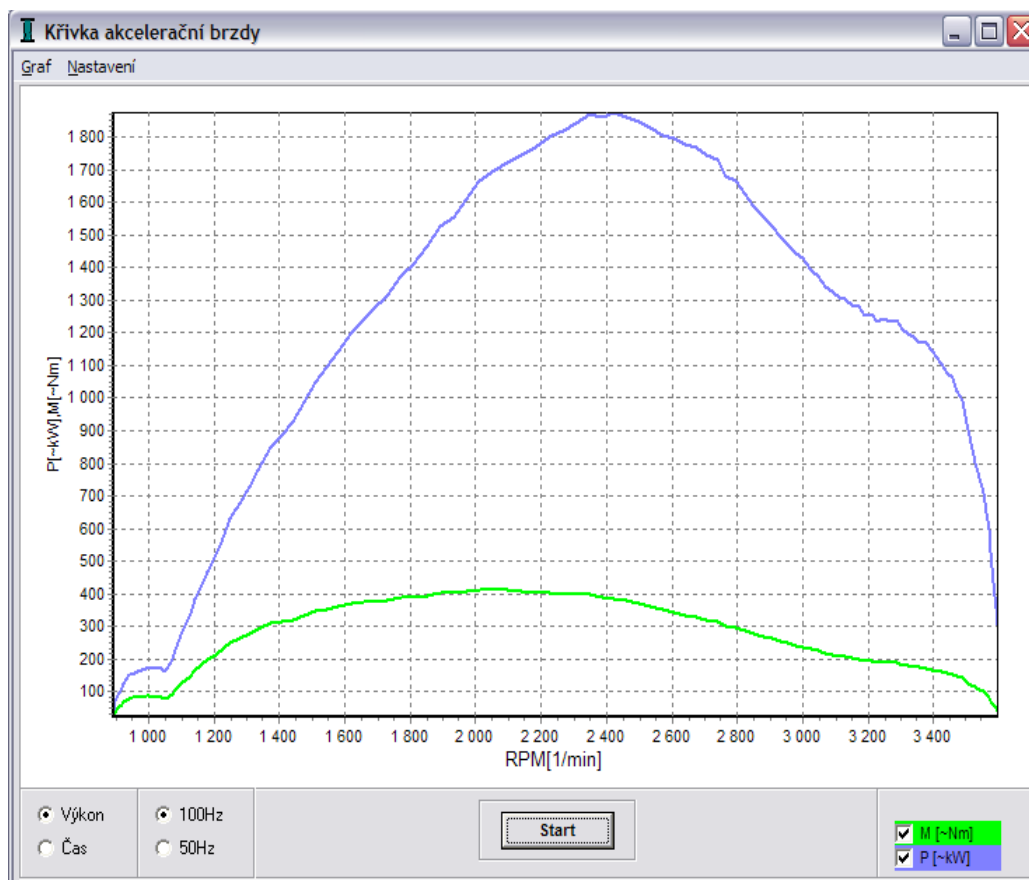

Power and torsional moment to the engine speed

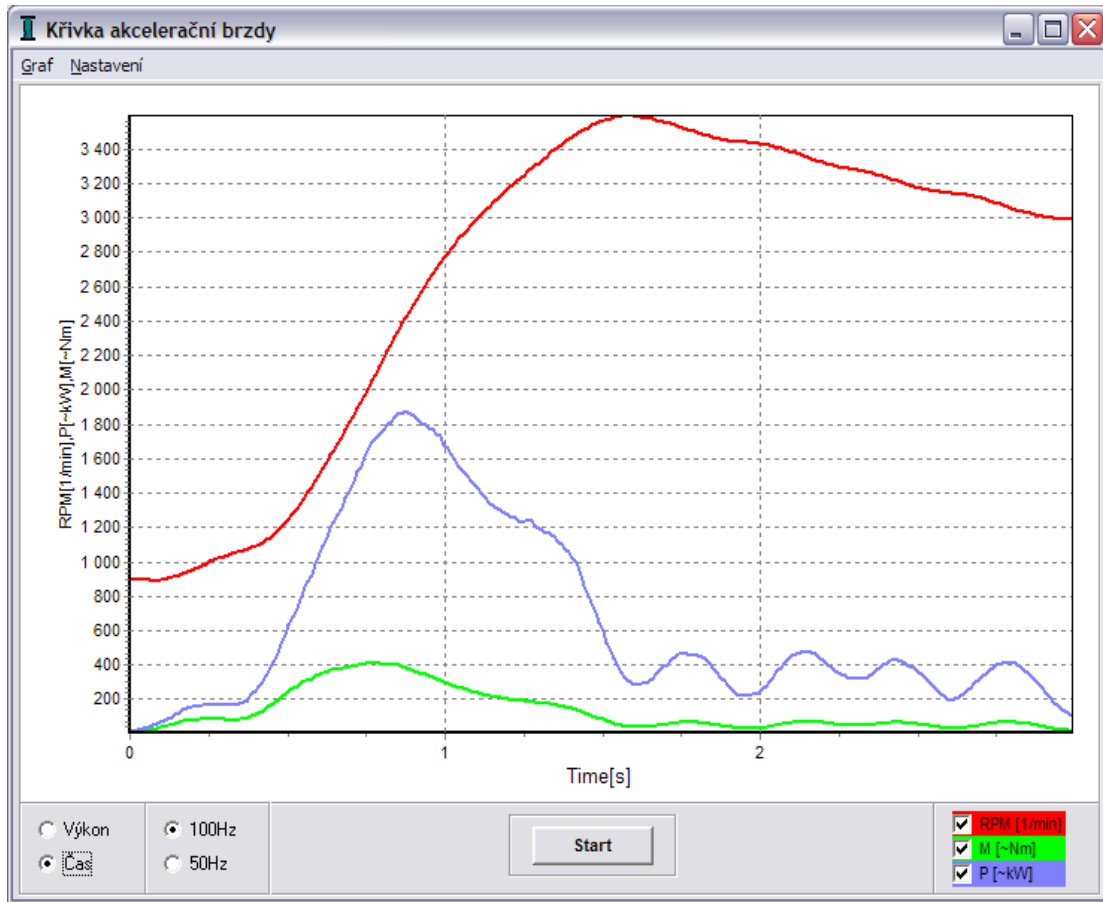

Engine speed, Power and Torsional moment in the Time

Questions to the Universal Ignition

- *What is the principle of directing the ignition advance?*
 - The directing of ignition advance is based on the exact delay of ignition from the very first signal in reading sensor. During the highest turns there is no time delay of the signal and that is why the advance is equal to the signal set in the reading sensor and then it is highest e.g. 30°. During the low turns the advance is lowered by the inserted time delay. All time delays are converted from the set ignition advance curve.

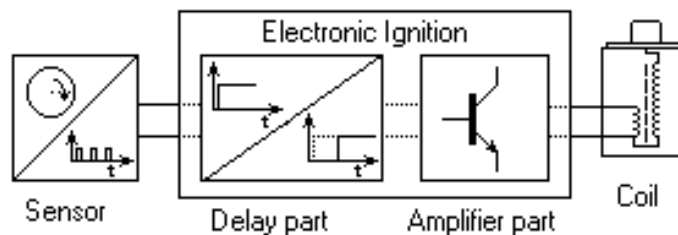

- *What pole is to be earth terminating?*
 - The motorbike types are usually terminated by the minus pole. This ignition can be terminated both plus or minus. If you have terminated the plus pole then you must change coil supply from minus to plus. Redundant minus wire from coil you can use as ignition unit supply.
- *Is there any predetermined curve of the ignition advance dependency on the turns that would respond to the values reached by the original arrange?*
 - The ignition includes the basic curve for the ignition advance directing that is possible to edit through the help of a personal computer. The ignition has an integrated optical turn reading sensor on the board. Instead of the original shaft it is necessary to install a shading sheet metal that will shadow the optical reading sensor by 180° and will divide the sparks into the each cylinder.
- *How is the ignition area protected against dust, vibrations, temperatures...?*
 - Mechanically it is protected by a protective epoxy varnish. All components are of SMD design that tolerates vibrations. The protective epoxy varnish also fixes the components firmly and absolutely prevents from any damage by vibrations, oil, water and dust.